



- DE/CH/AT** Montage- und Gebrauchsanleitung
- EN** Assembly and user manual
- FR** Instructions de montage et d'utilisation
- ES** Instrucciones de montaje y uso
- PT** Instruções de montagem e de utilização
- IT** Istruzioni per il montaggio e l'uso
- NL** Montage- en bedieningsinstructies
- DK** Montage- og betjeningsvejledning
- SE** Monterings- och bruksanvisningar
- NO** Monterings- og bruksanvisning
- FI** Kokoonpano- ja käyttöohjeet
- PL** Instrukcja montażu i obsługi
- CZ** Návod k montáži a obsluze
- HU** Összeszerelési és kezelési útmutató



TPMSR2417

**PRIMEYARD®**

## **⚠ HINWEIS:**

Dieses Seitendach ist speziell für den Einsatz in einem Gerätehaus konzipiert und darf nicht als eigenständiges Bauteil verwendet werden. Bitte beachten Sie daher unbedingt die Sicherheitshinweise und Montageanleitungen des Gerätehauses um eine sichere und ordnungsgemäße Verwendung zu gewährleisten.

## **⚠ NOTE:**

This side roof is specially designed for use in a shed and must not be used as a stand-alone component. It is therefore essential that you follow the safety instructions and assembly instructions for the shed to ensure safe and proper use.

## **⚠ REMARQUE:**

Ce toit latéral est spécialement conçu pour être utilisé dans un abri de jardin et ne doit pas être utilisé comme élément de construction autonome. Veuillez donc impérativement respecter les consignes de sécurité et les instructions de montage de l'abri de jardin afin de garantir une utilisation sûre et conforme.

## **⚠ NOTA:**

Este techo lateral está especialmente diseñado para su uso en un cobertizo y no debe utilizarse como componente independiente. Por lo tanto, es esencial que siga las instrucciones de seguridad y las instrucciones de montaje del cobertizo para garantizar un uso seguro y adecuado.

## **⚠ NOTA:**

Este teto lateral foi especialmente concebido para ser utilizado num telheiro e não deve ser utilizado como componente autónomo. Por conseguinte, é essencial seguir as instruções de segurança e as instruções de montagem do telheiro para garantir uma utilização segura e correta.

## **⚠ NOTA:**

Questo tetto laterale è stato progettato appositamente per l'uso in un capannone e non deve essere utilizzato come componente indipendente. È quindi essenziale seguire le istruzioni di sicurezza e di montaggio del capannone per garantire un uso sicuro e corretto.

## **⚠ OPMERKING:**

Dit zijdak is speciaal ontworpen voor gebruik in een schuur en mag niet als zelfstandig onderdeel worden gebruikt. Het is daarom essentieel dat u de veiligheidsinstructies en montagehandleiding van de schuur opvolgt voor een veilig en correct gebruik.

## **⚠ BEMÆRK:**

Dette sidetag er specielt designet til brug i et skur og må ikke bruges som en selvstændig komponent. Det er derfor vigtigt, at du følger sikkerhedsinstruktionerne og monteringsvejledningen til skuret for at sikre en sikker og korrekt brug.

## **⚠ OBS:**

Detta sidotak är speciellt utformat för att användas i ett skjul och får inte användas som en fristående komponent. Det är därför viktigt att du följer säkerhetsanvisningarna och monteringsanvisningarna för skjulet för att säkerställa säker och korrekt användning.

## **⚠ MERK:**

Dette sidetaket er spesialkonstruert for bruk i en bod og må ikke brukes som en frittstående komponent. Det er derfor viktig at du følger sikkerhetsinstruksjonene og monteringsanvisningen for skuret for å sikre trygg og riktig bruk.

## **⚠ HUOMAUTUS:**

Tämä sivukatto on suunniteltu erityisesti käytettäväksi vajassa, eikä sitä saa käyttää erillisenä osana. Siksi on tärkeää, että noudatat vajan turvallisuus- ja asennusohjeita turvallisen ja asianmukaisen käytön varmistamiseksi.

## **⚠ UWAGA:**

Ten dach boczny został specjalnie zaprojektowany do użytku w szopie i nie może być używany jako samodzielny element. W związku z tym, aby zapewnić bezpieczne i prawidłowe użytkowanie, należy bezwzględnie przestrzegać instrukcji bezpieczeństwa i montażu wiaty.

## **⚠ POZNÁMKA:**

Tato boční střecha je speciálně navržena pro použití v přístřešku a nesmí se používat jako samostatný prvek. Proto je nezbytné dodržovat bezpečnostní pokyny a pokyny k montáži přístřešku, aby bylo zajištěno bezpečné a správné používání.



## **⚠ MEGJEGYZÉS:**

Ezt az oldalsó tetőt kifejezetten fészerben való használatra tervezték, és nem szabad önálló alkatrészként használni. Ezért a biztonságos és megfelelő használat érdekében feltétlenül be kell tartani a fészer biztonsági utasításait és összeszerelési utasításait.

77263		x1	77275		x1
77264		x1	77271		x1
77287		x2	77285		x1
77281		x1	77286		x1
77282		x1	77283		x1
77288		x2	77284		x1
76033		x2	77289		x1

77232		x1	77280		x1
77184		x1	73121		x1
77290		x1			

72021	 M5*10	x26	71033	 D18/d6.5*1.5	x4
74053	 M4*12	x138	72028	 D12/d5*1.0	x10
71029	 M6*10	x10	77261	 M4*20	x4
72023	 M4*10	x15	77262	 D19/d7*4	x63
77198	 M5*35	x2	72026	 3#	x1
77199	 M5*35	x2	71036	 4#	x1
77200	 M5*65	x1	77182	 4#	x1
72022	 M5	x2	71035	 4#	x1

76070	 10-14#	x1	76069	 M8*100	x4
76063	 8#-10#	x1			

1

**Orange gefärbte Teile müssen im jeweiligen Bauschritt demontiert werden!**



Entfernen Sie die Schrauben!



2

**Orange gefärbte Teile müssen im jeweiligen Bauschritt demontiert werden!!**



4



Mit einem Hammer abklopfen





Bitte seien Sie vorsichtig  
(Bei der Arbeit Handschuhe tragen)





1



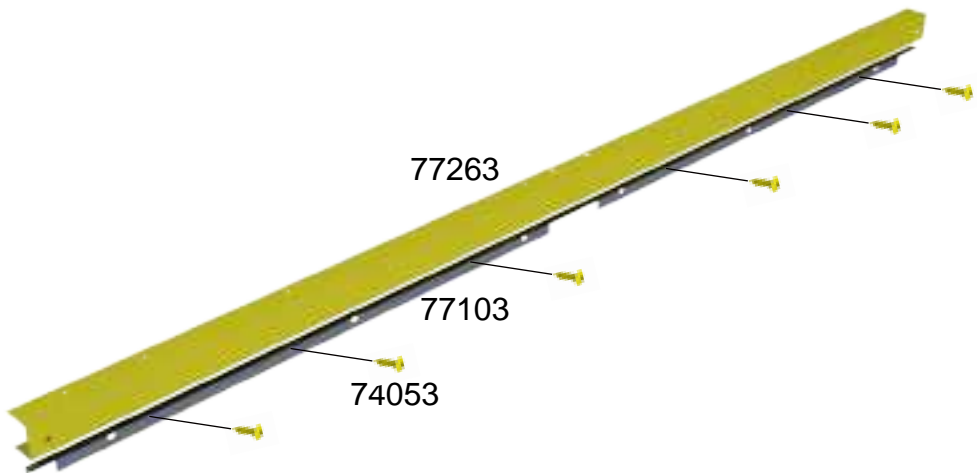
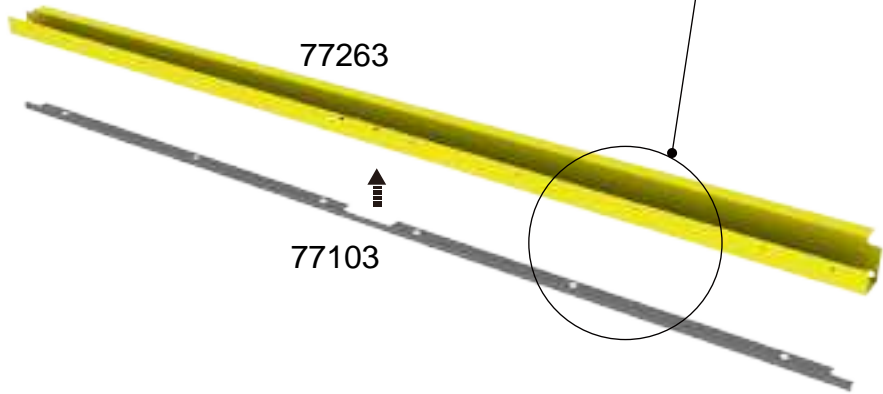
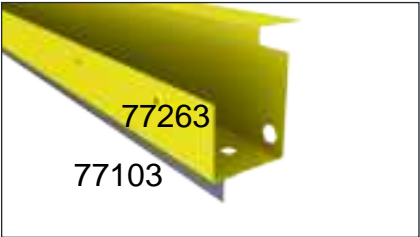

 77263	X1	M4*12	 74053	X6
--	----	-------	--	----

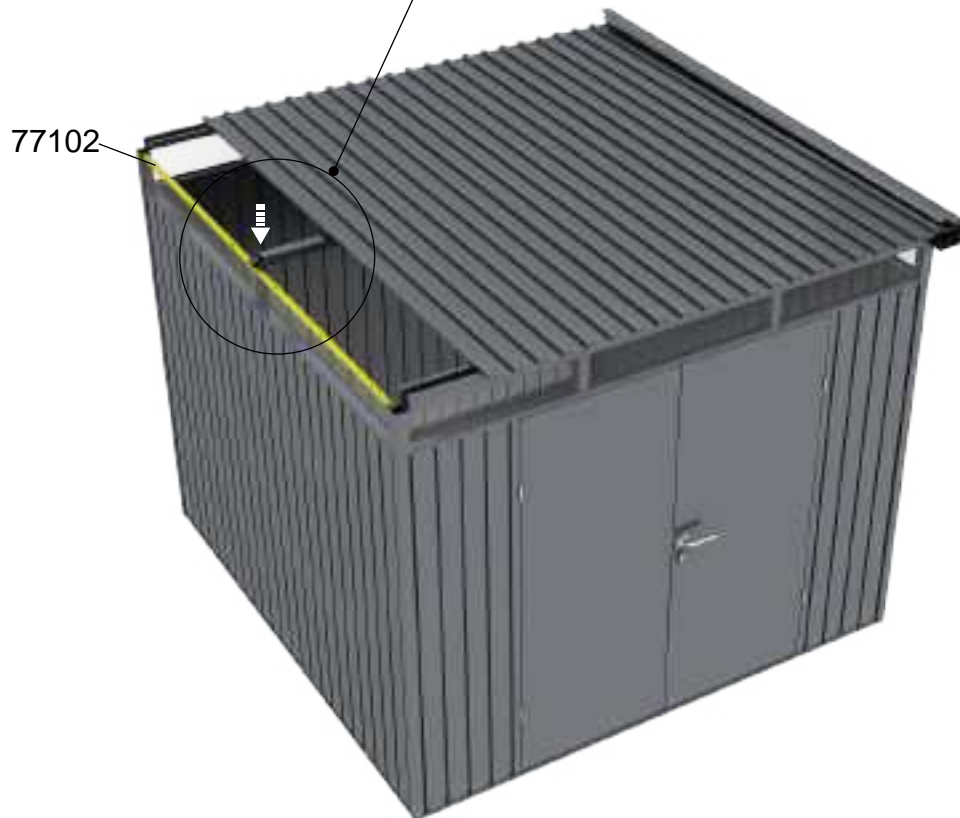
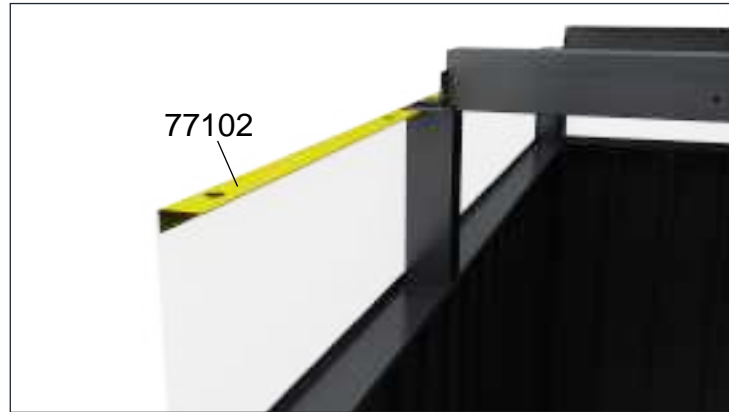

2





3

 77263	X1	M4*12	 74053	X8	M5*10	 72021	X4
M6*10	 71029	X2					



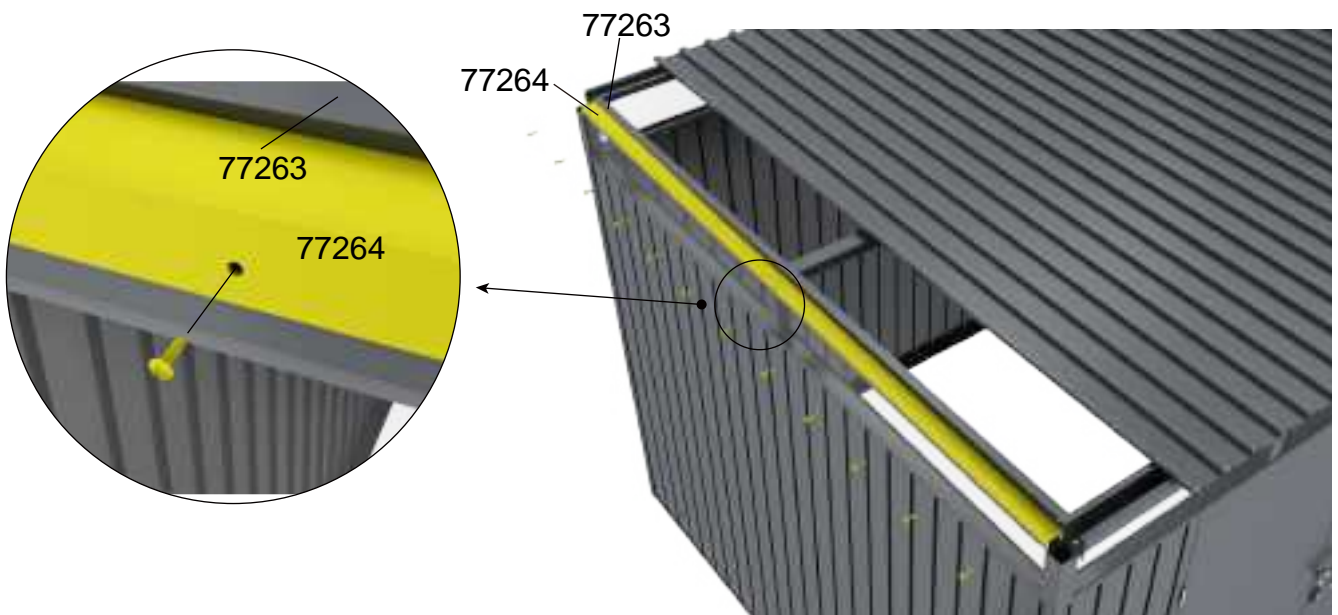
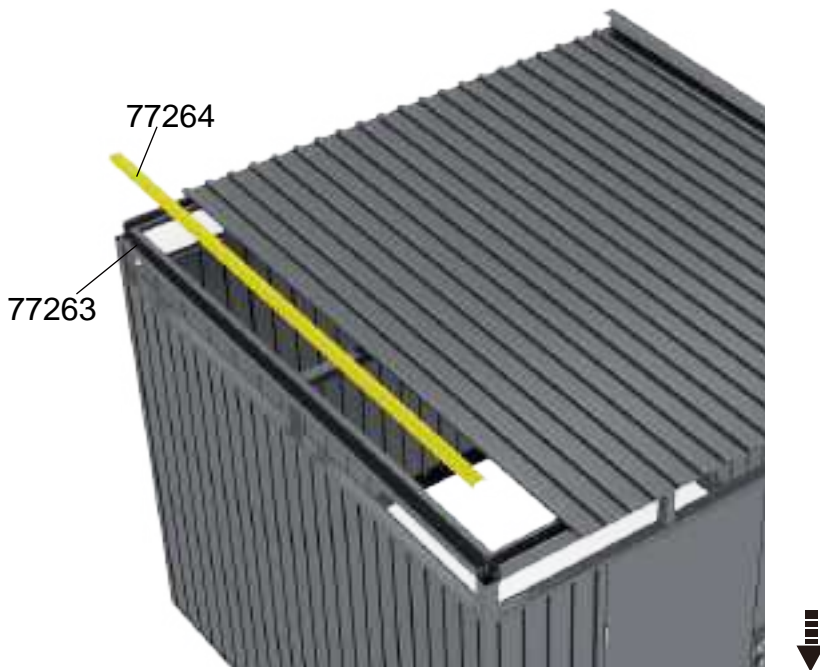

4

	X1	M4*12		X12
77264			74053	



5

	X2	M5*10		X8
77287			72021	

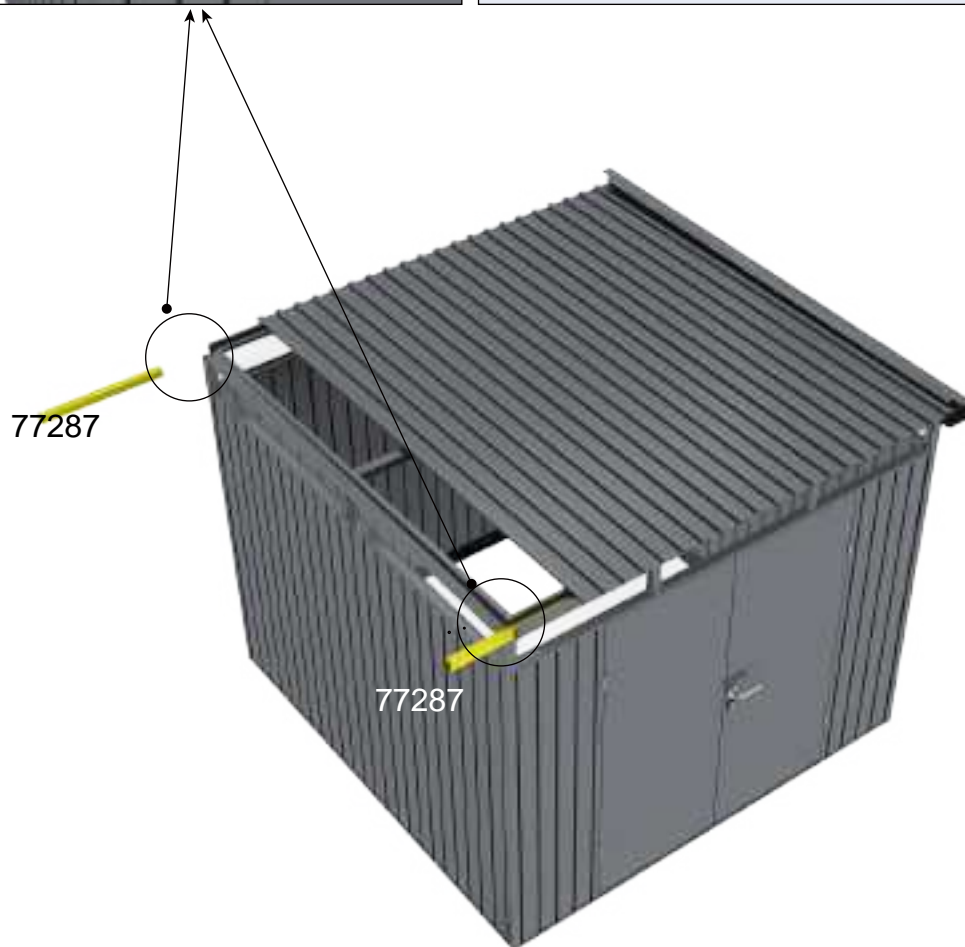





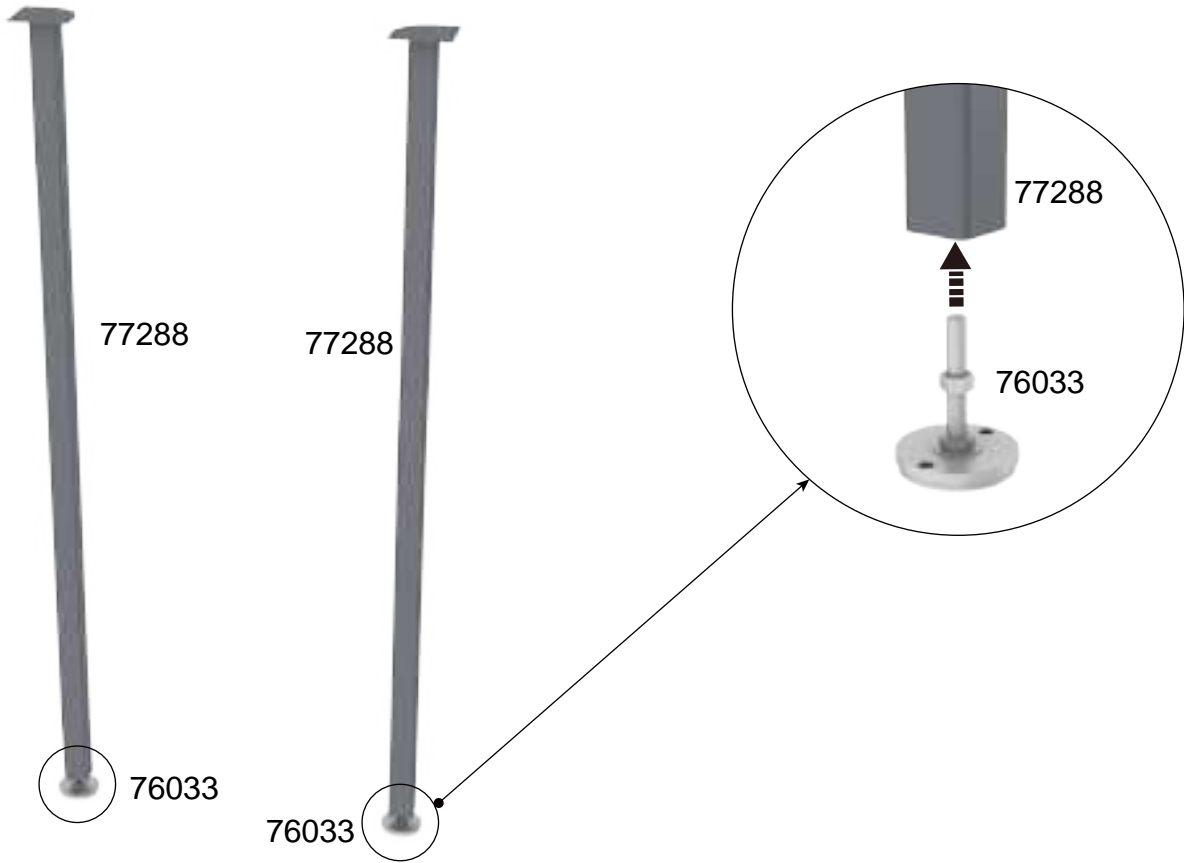
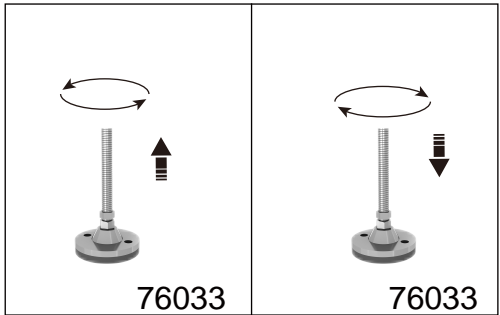
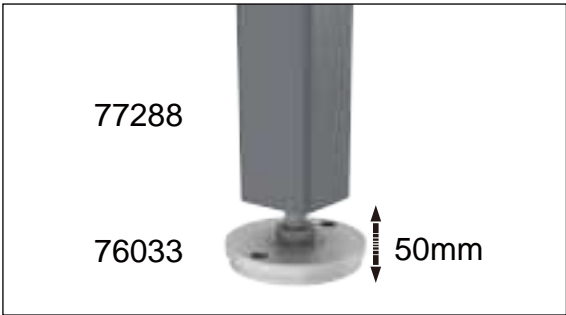

6

	X2		X2
77288		76033	



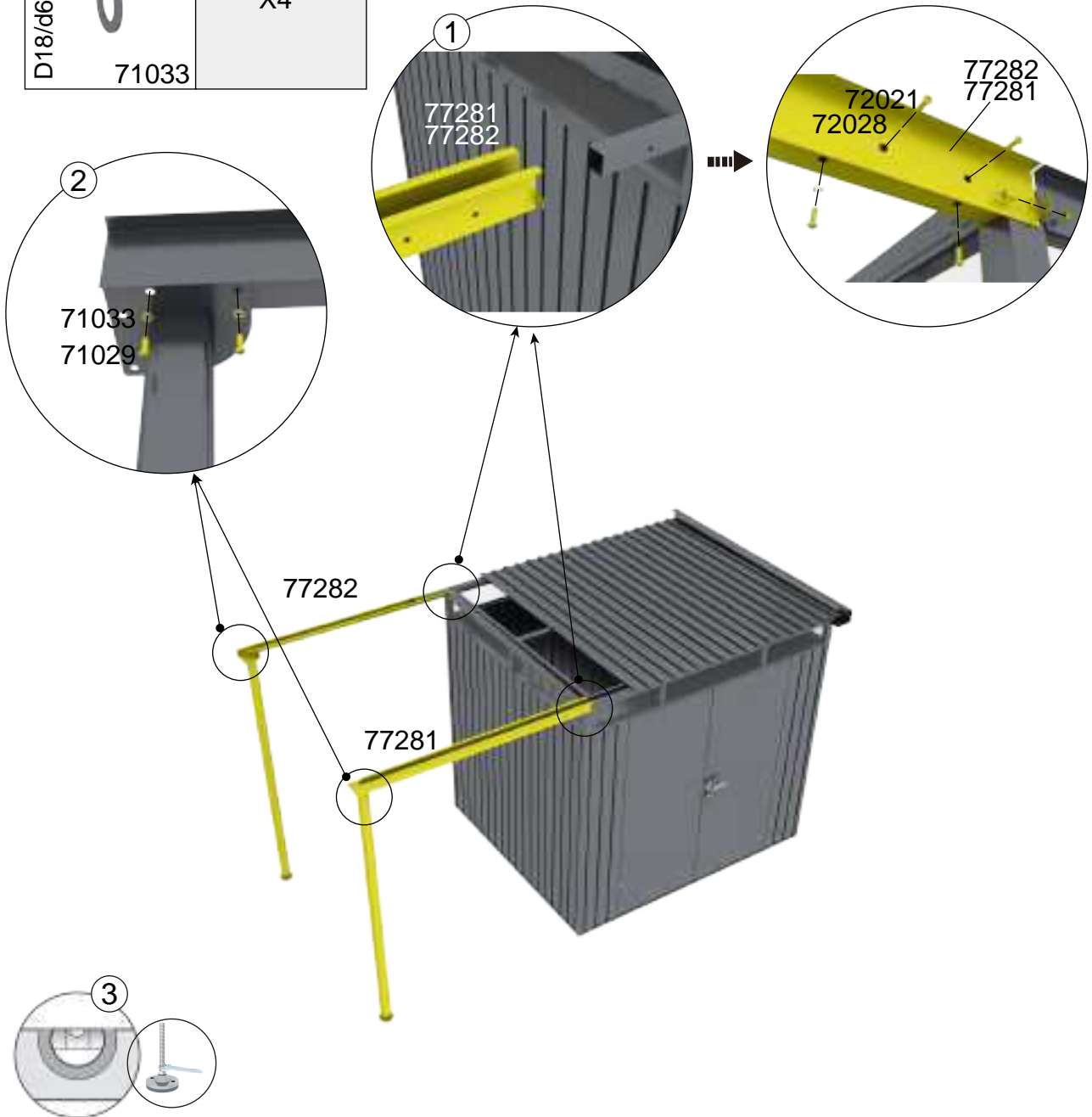

# 7

 77281	X1	 77282	X1	M5*10  72021	X10
M5  72022	X2	D12/d5*1.0  72028	X10	M6*10  71029	X4
D18/d6.5*1.5  71033	X4				







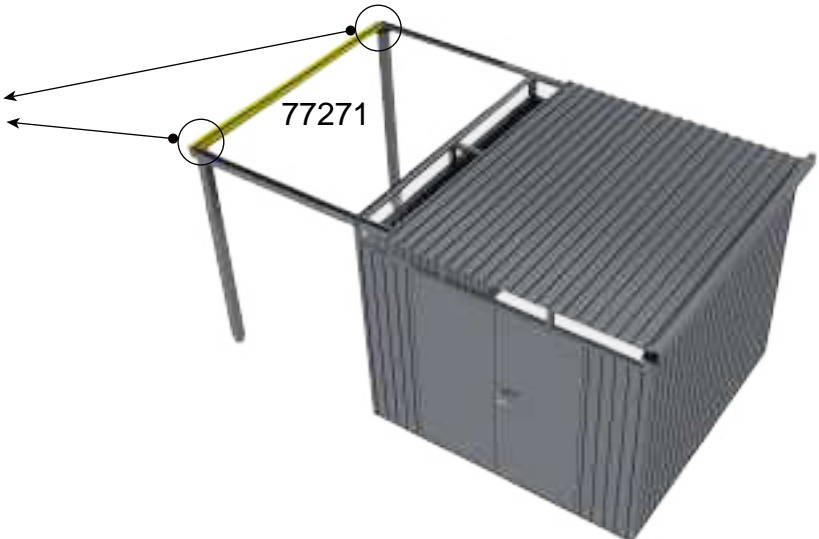
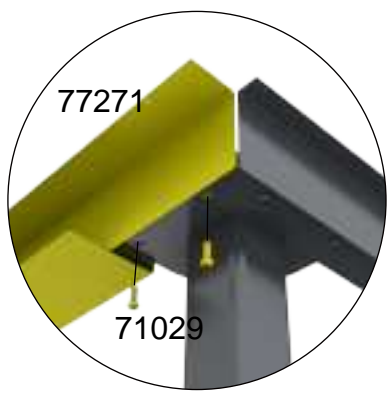
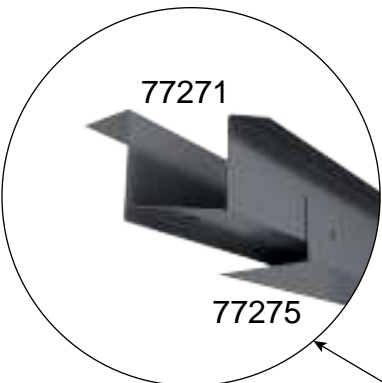
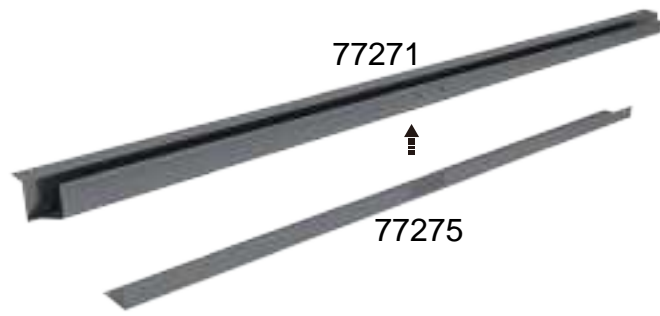

8

 77275	X1	 77271	X1	M6*10  71029	X4
M4*12  74053	X6				







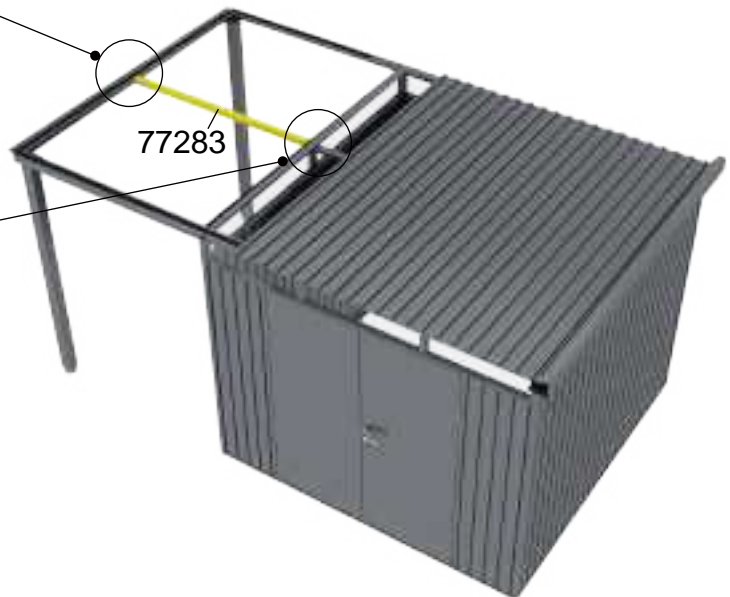
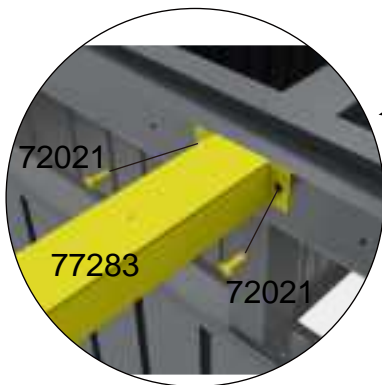
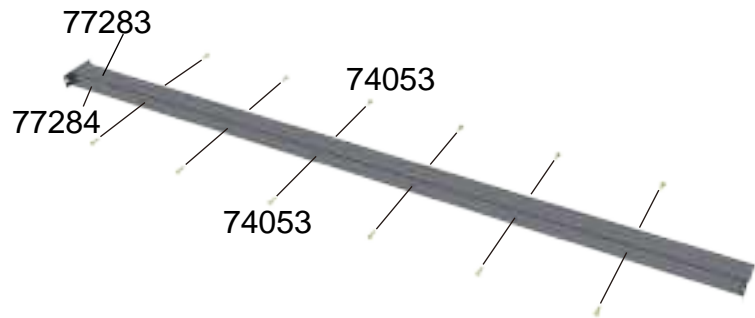

9

 77283	X1	 77284	X1	M4*12  74053	X14
M5*10  72021	X4				

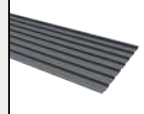

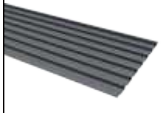

10

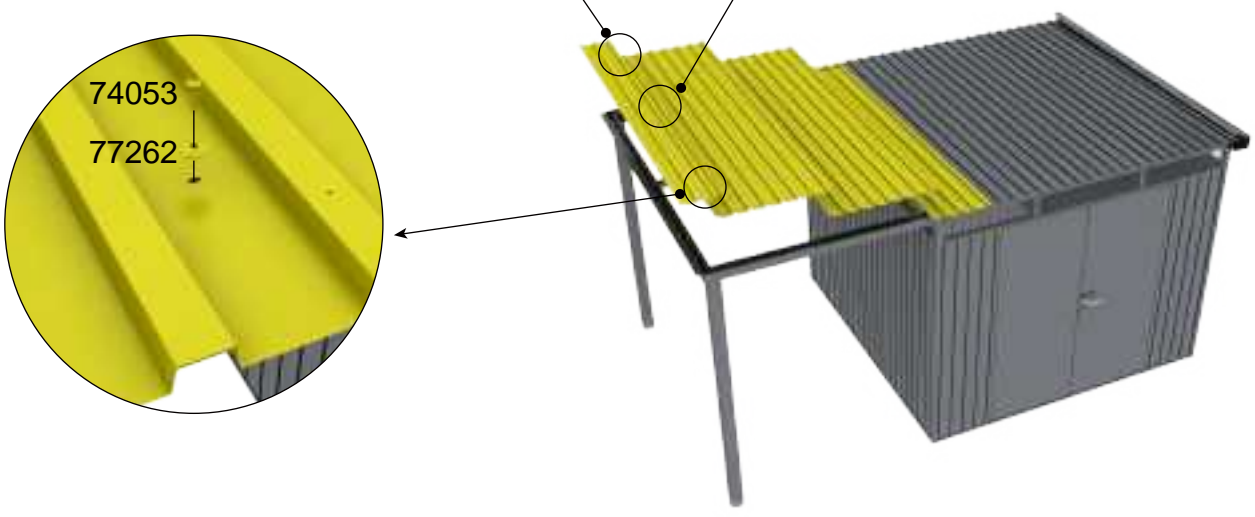
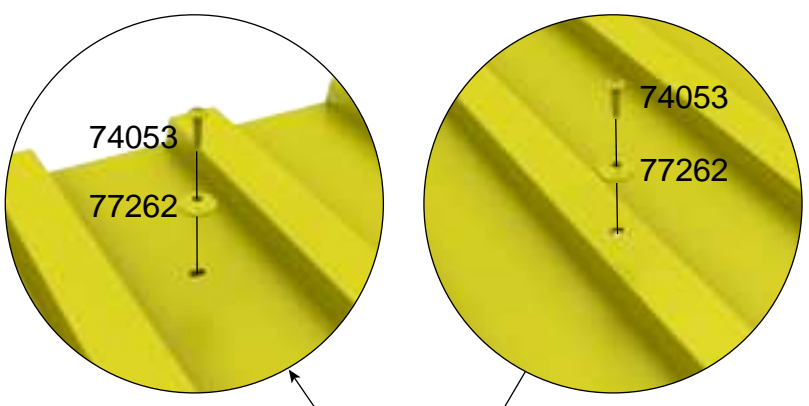
 77289	X1	 77184	X1	M4*12	 74053	X36
 77290	X1	 77262	X36			





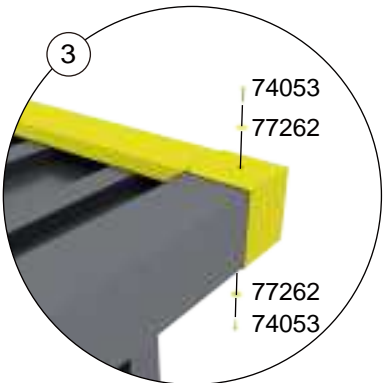
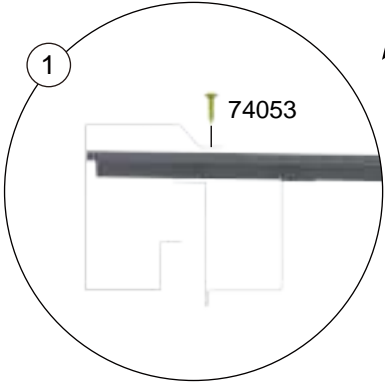
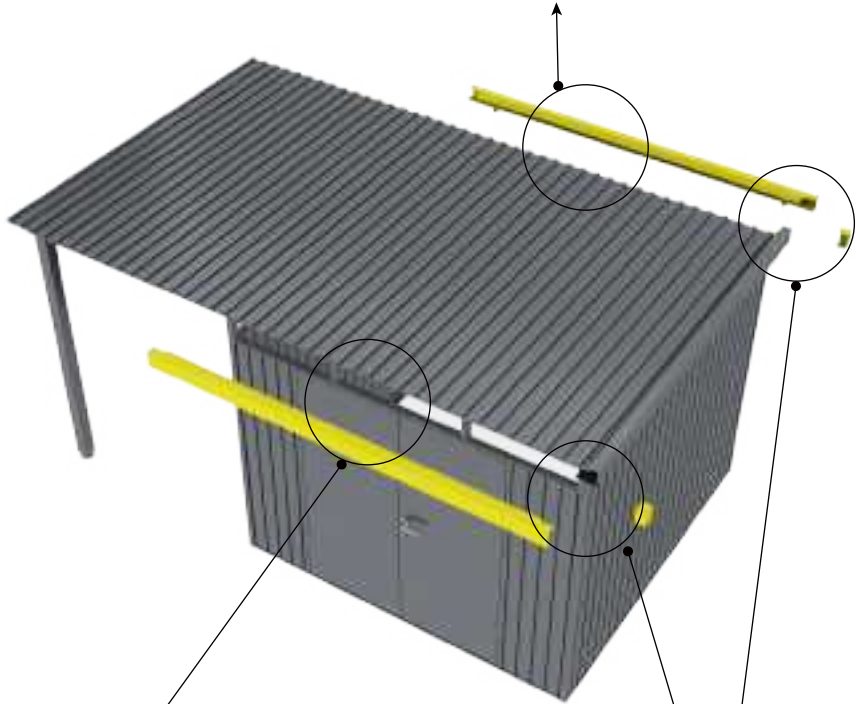
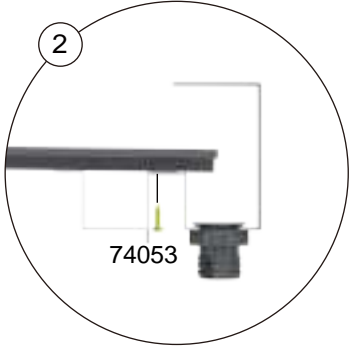

11

M4*12		X21		X4
	74053		77262	



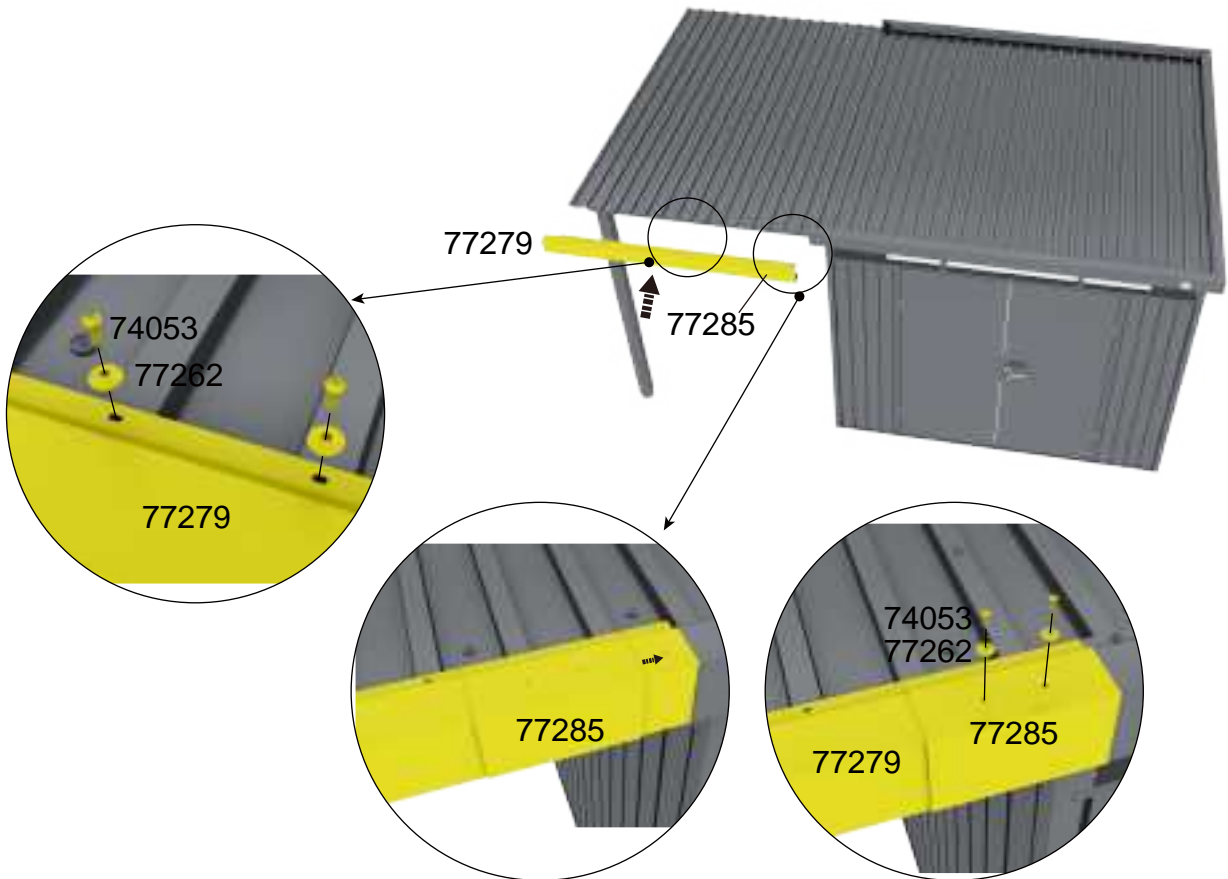
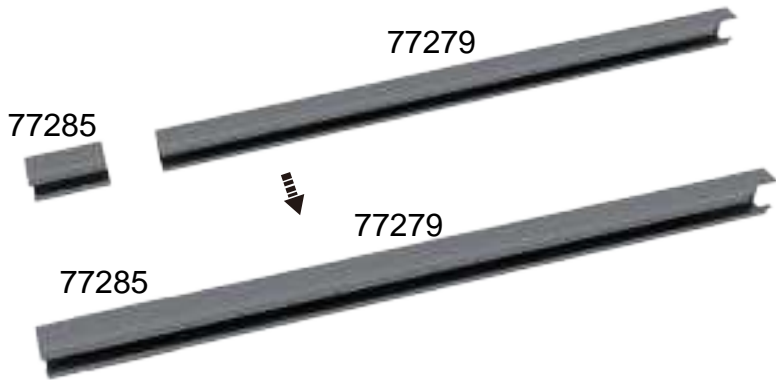

12

 77285	X1	 77279	X1	M4*12  74053	X17
 77262	X17				



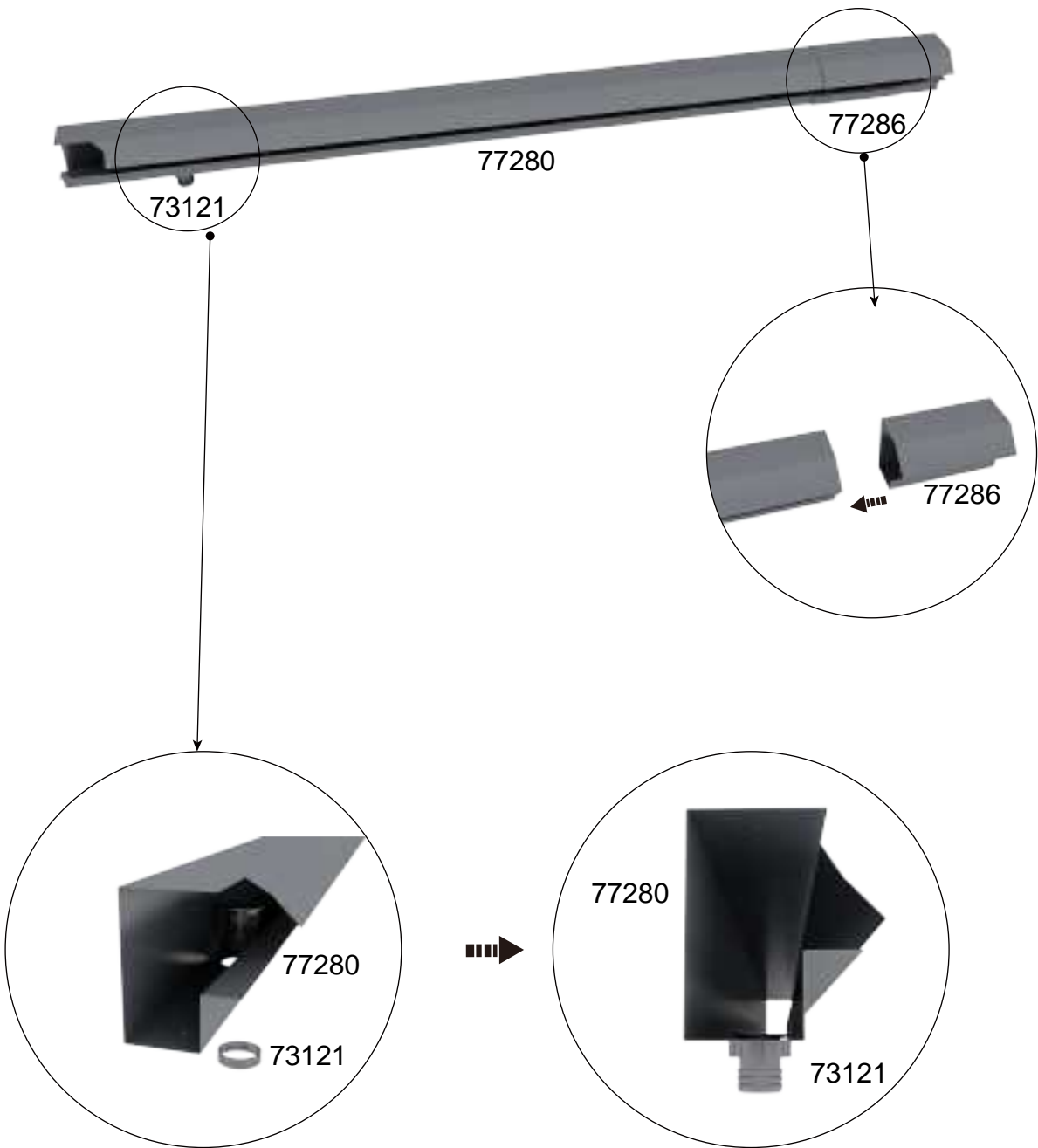

13

	X1		X1		X1
77286		77280		73121	



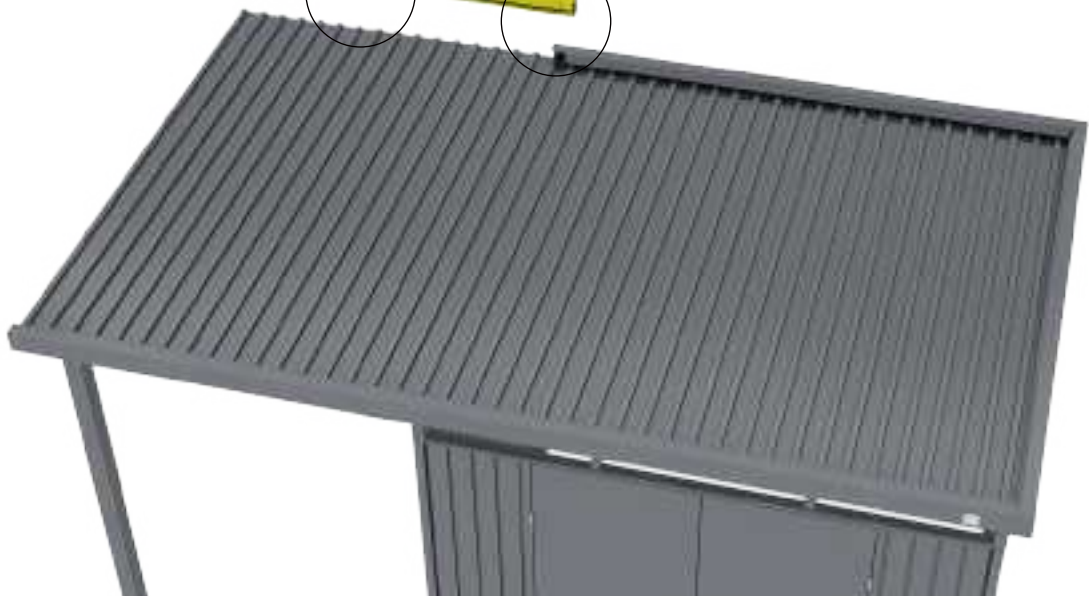
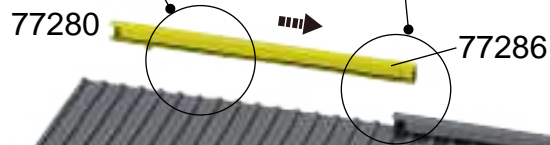
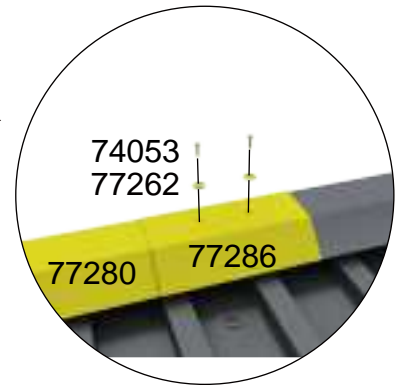
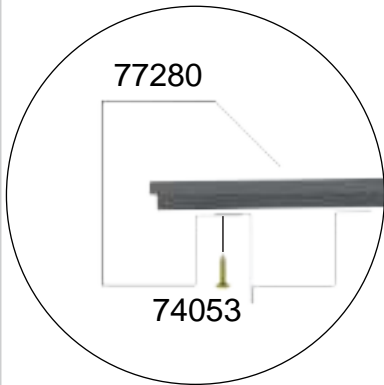

14

M4*12		X8		X2
	74053		77262	



**15**

M4*12		X10		X4
	74053		77262	

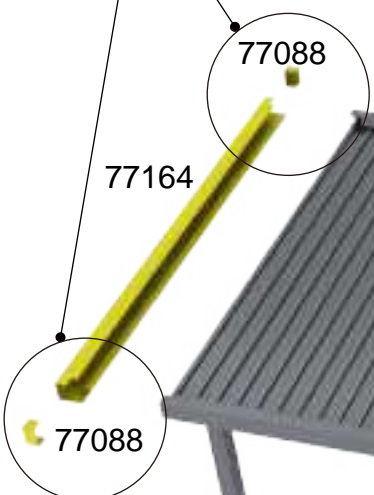
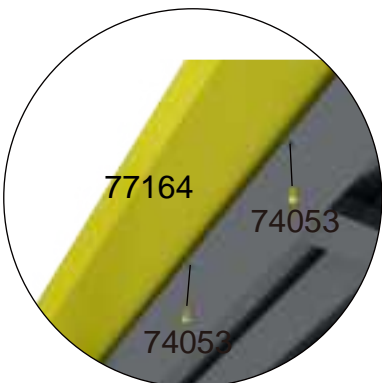
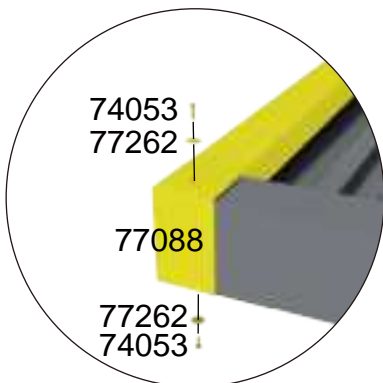



**16**

M8*100		X4
	76069	

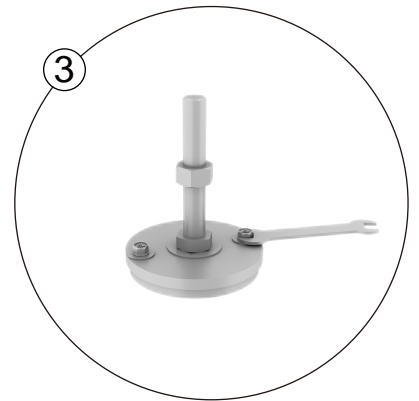
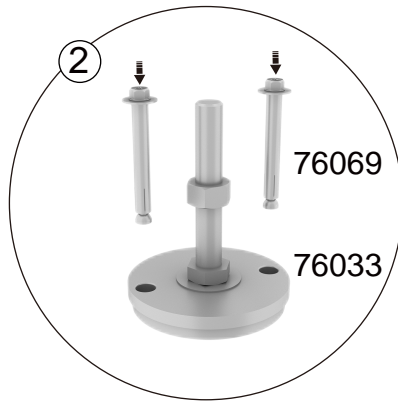
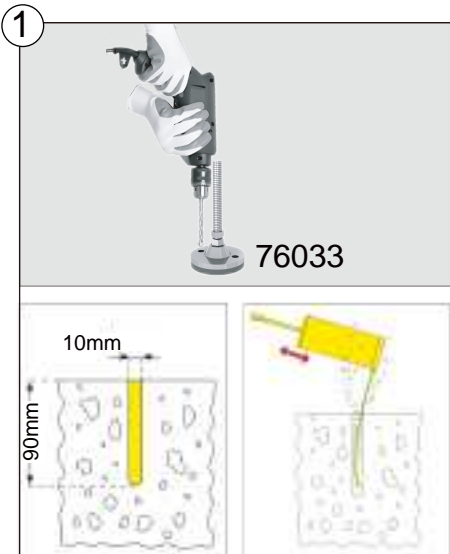











vertrieben durch  
**GFP Handels GesmbH**  
Passauerstraße 24  
A-4070 Eferding

**[www.gfp-international.com](http://www.gfp-international.com)**

**Toolport GmbH**  
Gutenbergring 1-5  
D-22848 Hamburg

**[www.toolport.de](http://www.toolport.de)**